

NEWMARKET PRE-CAST CONCRETE PRODUCTS LTD.

Telephone: 905-852-6111 ; Toll Free 1-800-263-1297

Model 4500 (1000 GAL) Septic Tank w/ 1350 (300 GAL) Pumping Chamber - 1 Piece Unit Working Capacity 4516 Litres (993 Gal)

- This tank design is a one piece unit. Tank top is sealed with a fibrous mastic sealant
- Tanks are cast with 35 MPA strength concrete at 7 days with 5-7% air
- 3.0 Kg. structural fibre added to concrete. ASTM C 1116
- Lid has 10m Pre-manufactured welded wire
- 10m Continuous rebar placed at top of wall. Rebar Cover 25mm
- Tanks conform to National Standards of Canada CAN/CSA B66-16
- Non-sulphate resistant concrete
- Standard (3) 100mm Inlets.
- Chamber divider monolithically cast with structure.

Bare Base Weight.....4837 Kg (10,665 Lbs)
Lid Weight.....1418 Kg (3,128 Lbs)
Total Tank Weight.....6255 Kg (13,793 Lbs)

Notes

1. Two 100 x 150mm partition flow through holes
2. Concrete inlet baffle is pre-fitted to accommodate three 100mm flexible rubber connections
3. 100mm septic outlet fitted with effluent filter that meets Ontario Building Code, Pump tank fitted with 50mm rubber connection
4. Cast in place 610mm ID plastic riser with plastic lid secured with stainless steel fasteners extending 100mm above top
5. Pre-installed pump pad 406mm x 406mm, 64mm tall

Designed for up to one metre burial over top of tank - Deep burial and vehicle traffic tanks are available upon request. Specialty conformations may be possible

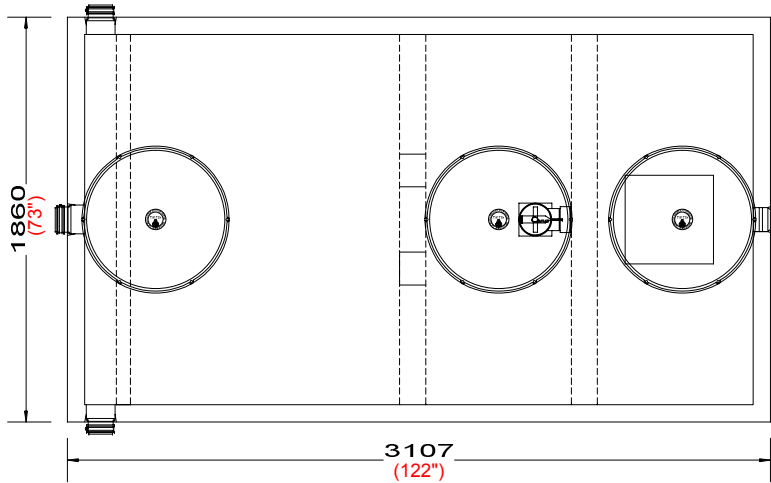

Top Section

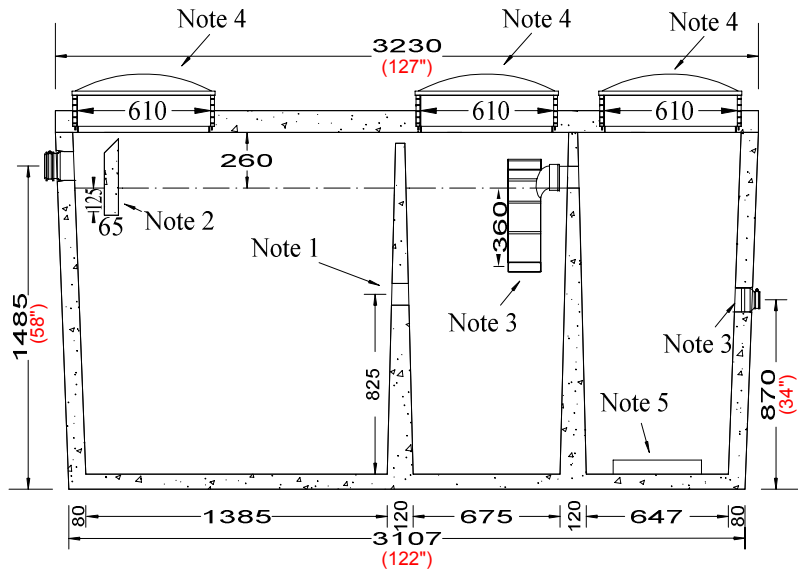

Side Elevation Section

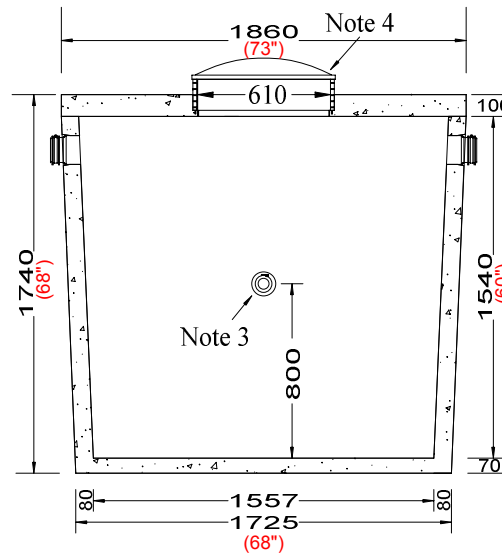

End Elevation Section

Tank Markings Observed:
Inlet & Outlet is Marked.
Tank is marked on tank lid - Inlet End

NPCP
2017 SEPTIC 4500
B.D. 1 METRE
1200 LIQUID DEPTH
WC 4516
NON-SULPHATE
AGINP
PML

NPCP
2017 PUMP TK 1350
B.D. 1 METRE
WC 1198
NON-SULPHATE
AGINP
PML