

Top View

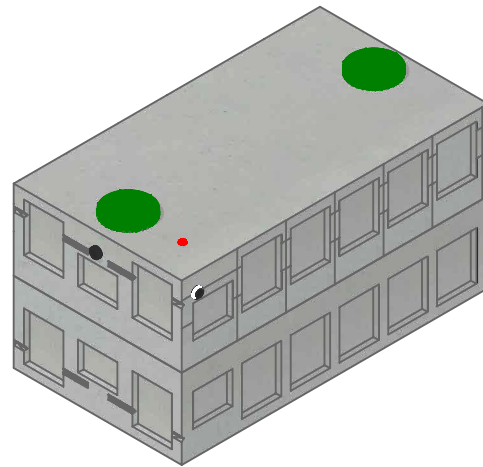

Isometric View

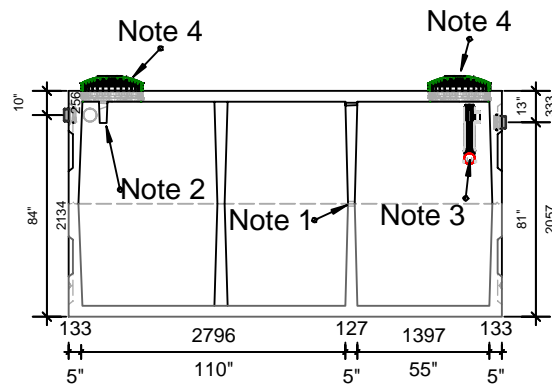

Side View

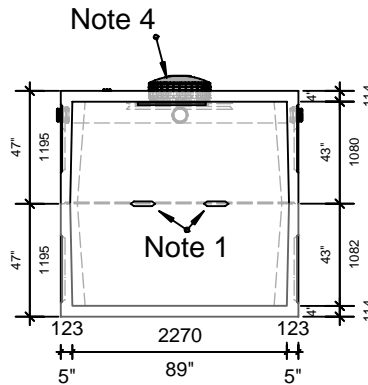

End View

WORKING CAPACITY: 18,398L (4047 IG)

Bare Base Weight.....7705 Kg (16,986 Lbs)
 Lid Weight.....7470 Kg (16,469 Lbs)
 Total Tank Weight.....15,175 Kg (33,455 Lbs)

Notes

1. Two 105mm x 150mm partition flow through
2. Concrete inlet baffle is pre-fitted to accommodate three 100mm flexible rubber connections
3. Outlet contains one 100mm flexible rubber connection fitted with PL-122 Effluent Filter
4. Cast in place 610mm ID Tuf-tite riser with dome lid secured with stainless steel fasteners extending 67mm above top

Tank Markings Observed:
 Inlet & Outlet are Marked

Tank is Marked on Tank Lid - Inlet End

NPCP
 SEPTIC 18000 L
 B.D. 1 METRE
 1200 LIQUID DEPTH
 WC 18398
 NON SULPHATE
 AGINP
 PML

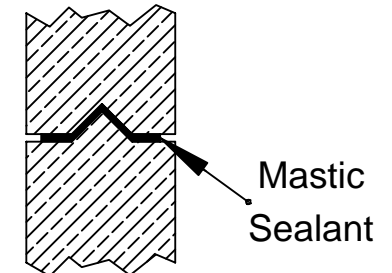

Tongue and Groove Joint



20 Victoria St
 Uxbridge, ON L9P 1N4
 Tel: 905-852-6111
 Toll Free: 1-800-263-1297
 Fax: 905-852-4340
 Info@Newmarketprecast.com
 Newmarketprecast.com

Model 18000 Septic 4000 Imperial Gallon

Designed for up to **One Metre** burial over top of tank - Deep burial and vehicle traffic tanks are available upon request. Specialty conformations may be possible

- This tank design is installed in multiple units
- Each unit is tongue and groove design and is sealed with a fibrous mastic sealant
- Tanks are cast with minimum 45 MPA/6500 PSI strength at 7 days with 5-7% air
- Top section steel reinforced with 10m rebar, spaced at 305mm in each direction
- Bottom section steel reinforced with 15m rebar, spaced at 305mm in each direction
- Rebar Cover Minimum 25mm
- Tanks conform to National Standard of Canada CAN/CSA B66-16
- Non-sulphate resistant concrete
- Chamber divider monolithically cast in with structure
- Standard three 100mm Inlets and one 100mm Outlet with filter that meets building code